

Drive axle with
maintenance-free
wet-disc brake

Electrically applied
parking brake

Optimum visibility
in all directions

High throughput levels

Robust and efficient
Kubota industrial motors

Functional, safe and
low-vibration workstation



DFG/TFG 425/430/435

**Diesel and LPG forklifts with hydrodynamic drive
(Torque Converter) (2,500/3,000/3,500 kg)**

Our sturdy, universal trucks with torque converters (in short: converters) offer you high throughputs for all transport duties. The strengths of the converter can be clearly seen especially over medium and long-distance routes; smooth and judder-free operation and optimum efficiency at medium and high speeds.

Even at low speeds, the globally proven Kubota motors offer high torque. This reduces fuel consumption and minimises noise development. The motors have been specially designed for use in forklift trucks and are characterised by their high degree of reliability and long service life.

Our drive axle with integrated, wear-free wet-disc brakes represents optimised efficiency, outstanding reliability and low service costs. The braking effect is not negatively affected by ambient conditions. The enclosed design makes sure of this.

The operator's cab is functionally designed with the operator in mind. Visibility in all directions is outstanding. This guarantees focused work and the best conditions for high productivity throughout the shift.

Thanks to the special counterweight design, the truck's centre of gravity is low and in an ideal physical location between the axles. This results in above-average stability and driving safety.

**JUNGHEINRICH**

DFG/TFG 425/430/435

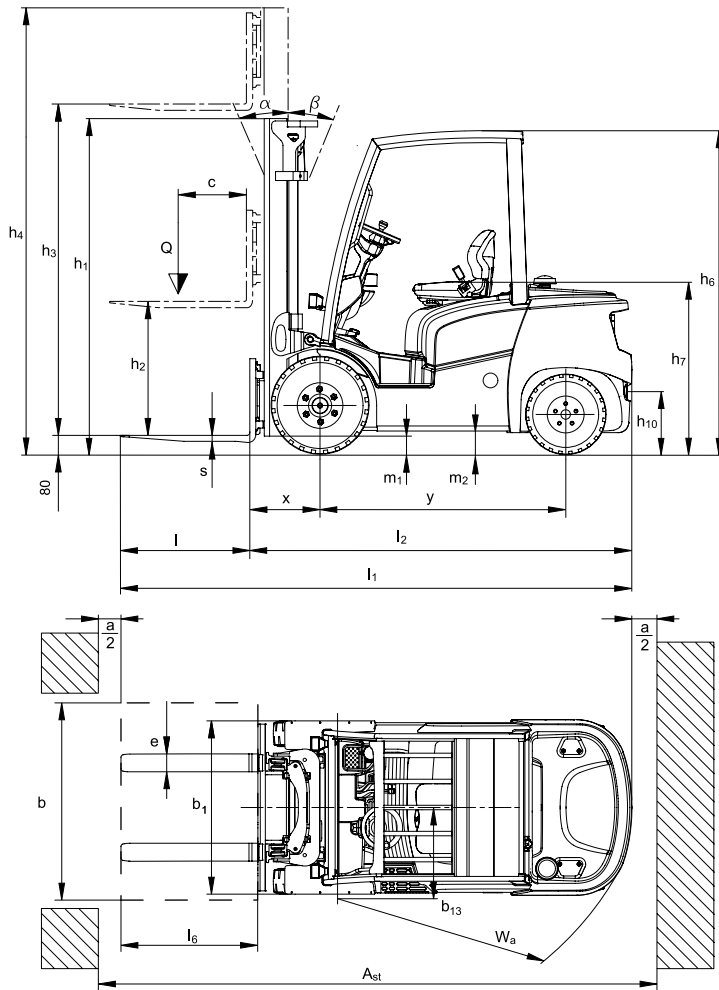

Capacity (kg)

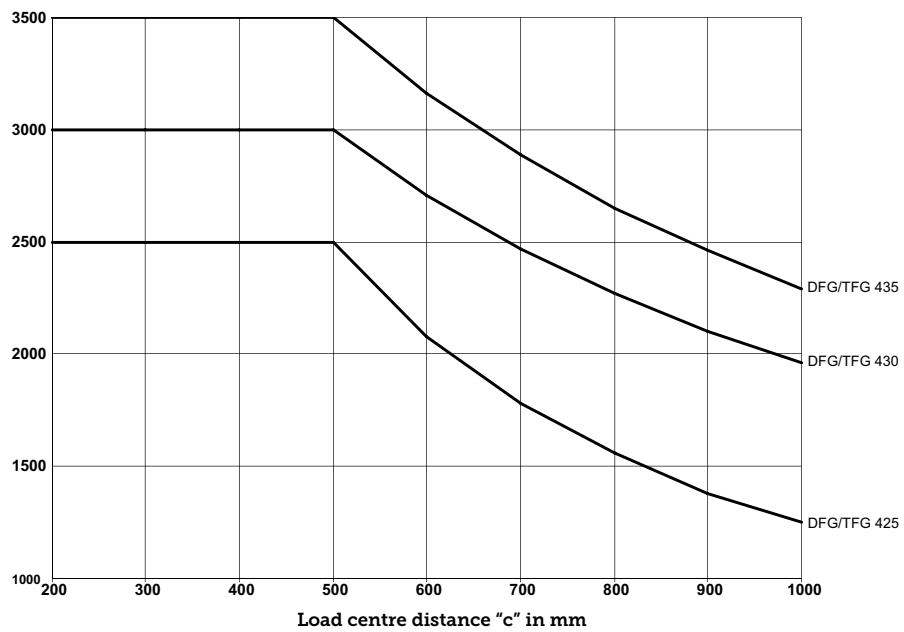

DFG/TFG 425/430/435

Standard mast designs DFG 425/DFG 430/DFG 435/TFG 425/TFG 430/TFG 435												
	Lift h_3 (mm)	Lowered mast height h_1 (mm)			Free lift h_2 (mm)			Extended mast height h_4 (mm)			Mast tilt forward / back α/β (°)	
		DFG 425 / TFG 425	DFG 430 / TFG 430	DFG 435 / TFG 435	DFG 425 / TFG 425	DFG 430 / TFG 430	DFG 435 / TFG 435	DFG 425 / TFG 425	DFG 430 / TFG 430	DFG 435 / TFG 435	DFG 425 / DFG 430 / TFG 425 / TFG 430	DFG 435 / TFG 435
		Duplex ZT	2900	2129	2122	2201	150	150	150	3502	3659	3689
	3100	2229	2222	2301	150	150	150	3702	3859	3889	6/8	6/8
	3300	2329	2322	2401	150	150	150	3902	4059	4089	6/8	6/8
	3500	2429	2422	2501	150	150	150	4102	4259	4289	6/8	6/8
	3700	2529	2522	2601	150	150	150	4302	4459	4489	6/8	6/8
	4000	2679	2672	2751	150	150	150	4602	4759	4789	6/8	6/8
	4300	2879	2872	2951	150	150	150	4902	5059	5089	6/8	6/8
	4500	2979	2972	3051	150	150	150	5102	5259	5289	6/8	6/6
	4700	3075	3075	3155	150	150	150	5350	5460	5490	6/6	6/6
	5000	3225	3225	3305	150	150	150	5650	5760	5790	6/6	6/6
	5500	3525	3525	3605	150	150	150	6200	6260	6290	6/6	6/6
	5800	3675	3675	3755	150	150	150	6500	6560	6590	6/6	6/6
	6000	3775	3775	3855	150	150	150	6700	6760	6790	6/6	6/6
Duplex ZZ	3100	2194	2187	2266	1614	1448	1497	3680	3839	3869	6/8	6/8
	3300	2294	2287	2366	1714	1548	1597	3880	4039	4069	6/8	6/8
	3500	2394	2387	2466	1814	1648	1697	4080	4239	4269	6/8	6/8
	3700	2494	2487	2566	1914	1748	1797	4280	4439	4469	6/8	6/8
	4000	2644	2637	2716	2064	1898	1947	4580	4739	4769	6/8	6/8
Triplex DZ	4400	2094	2087	2166	1514	1348	1397	4980	5139	5169	6/8	6/6
	4700	2194	2187	2266	1614	1448	1497	5280	5439	5469	6/6	6/6
	5000	2294	2287	2366	1714	1548	1597	5580	5739	5769	6/6	6/6
	5500	2494	2487	2566	1914	1748	1797	6080	6239	6269	6/6	6/6
	6000	2694	2687	2766	2114	1948	1997	6580	6739	6769	6/6	6/6
	6500	2894	2887	2966	2314	2148	2197	7080	7239	7269	6/6	6/6
	7000	3094	3087	3166	2514	2348	2397	7580	7739	7769	6/6	6/6
	7500	3294	3287	3366	2714	2548	2597	8080	8237	8269	6/6	6/6

Technical data in line with VDI 2198

			Jungheinrich			
			DFG 425	DFG 430	DFG 435	
Identification	1.1	Manufacturer (abbreviation)		Jungheinrich		
	1.2	Model		DFG 425	DFG 430	DFG 435
	1.3	Drive		Diesel		
	1.4	Manual, pedestrian, stand-on, seated, order picker operation		seat		
	1.5	Load capacity/rated load	Q t	2.5	3	3.5
	1.6	Load centre distance	c mm	500		
	1.8	Load distance	x mm	472 ¹⁾	493 ²⁾	498 ²⁾
	1.9	Wheelbase	y mm	1,650	1,700	1,780
	Weights	2.1	Net weight	kg	3,660	4,190
2.2		Axle loading, laden front/rear	kg	5,480 / 680	6,390 / 800	7,170 / 900
2.3		Axle loading, unladen front/rear	kg	1,510 / 2,150	1,640 / 2,550	1,710 / 2,860
Wheels / frame	3.1	Tyres		Pneumatic		
	3.2	Tyre size, front	mm	7.00-12	27x10-12	27x10-12
	3.3	Tyre size, rear	mm	6.00x9	6.50x10	6.50x10
	3.5	Wheels, number front/rear (x = driven wheels)		2x/2		
	3.6	Tread width, front	b ₁₀ mm	990	1,034	1,034
	3.7	Tread width, rear	b ₁₁ mm	940		
	Basic dimensions	4.1	Tilt of mast/fork carriage forward/backward	α/β °	6/8	
4.2		Mast height (lowered)	h ₁ mm	2,129	2,122	2,201
4.3		Free lift	h ₂ mm	150		
4.4		Lift	h ₃ mm	2,900		
4.5		Extended mast height	h ₄ mm	3,502	3,659	3,689
4.7		Height of overhead guard	h ₆ mm	2,175	2,180	2,180
4.8		Seat height/standing height	h ₇ mm	1,130	1,135	1,135
4.12		Coupling height	h ₁₀ mm	420	430	430
4.19		Overall length	l ₁ mm	3,617	3,768	3,863
4.20		Length to face of forks	l ₂ mm	2,567	2,718	2,813
4.21		Overall width	b ₁ /b ₂ mm	1,192	1,296	1,296
4.22		Fork dimensions	s/e/l mm	40 / 100 / 1,050	45 / 125 / 1,050	50 / 125 / 1,050
4.23		Fork carriage ISO 2328, class/type A, B		2A	3A	3A
4.24		Fork carriage width	b ₃ mm	1,120		
4.31		Floor clearance with load under mast	m ₁ mm	106	104	131
4.32		Ground clearance, centre of wheelbase	m ₂ mm	141	155	153
4.33		Aisle width for pallets 1000 x 1200 crossways	Ast mm	3,987	4,133	4,248
4.34		Aisle width for pallets 800 x 1200 lengthways	Ast mm	4,187	4,333	4,448
4.35	Turning radius	W _a mm	2,315	2,440	2,550	
4.36	Smallest turning radius	b ₁₃ mm	720	730	750	
Performance data	5.1	Travel speed, laden/unladen	km/h	17 / 18		
	5.2	Lift speed, laden/unladen	m/s	0.55 / 0.57	0.58 / 0.6	0.48 / 0.5
	5.3	Lowering speed, laden/unladen	m/s	0.55 / 0.55		
	5.5	Drawbar pull, laden/unladen	N	18,000		
	5.7	Gradeability, laden/unladen	%	24 / 27	20 / 26	18 / 24
	5.9.2	Acceleration time laden/unladen to 15 m	S	5.4 / 4.8	5.6 / 4.8	5.8 / 5
	5.10	Service brake		hydraulic		
5.11	Parking brake		hydraulic			
Combustion engine	7.1	Engine manufacturer / type		Kubota V2403-M-T		
	7.2	Engine output according to ISO 1585	kW	36.5		
	7.3	Rated speed	/min	2,200		
	7.4	No. of cylinders		4		
	7.4.1	Cubic capacity	cm ³	2,434		
	7.5.1	Fuel consumption as per EN 16796	l/h	3	3.3	3.5
		CO- Equivalent as per EN 16796	kg/h	9.5	10.5	11.1
Misc.	8.1	Type of drive control		hydrodynamic		
	8.2	Working pressure for attachments	bar	210		
	8.3	Oil flow for attachments	l/min	40		
	8.4	Sound pressure level at operator's ear as per EN 12053	dB (A)	82		
	8.5	Trailer coupling, model/type DIN		Bolt		
	8.6	Steering		hydraulic		

¹⁾ + 12 mm with integrated sideshift

²⁾ + 15 mm with integrated sideshift

Technical data in line with VDI 2198

				Jungheinrich		
				TFG 425	TFG 430	TFG 435
Identification	1.1	Manufacturer (abbreviation)		Jungheinrich		
	1.2	Model				
	1.3	Drive		LPG		
	1.4	Manual, pedestrian, stand-on, seated, order picker operation		seat		
	1.5	Load capacity/rated load	Q t	2.5	3	3.5
	1.6	Load centre distance	c mm	500		
	1.8	Load distance	x mm	472 ¹⁾	493 ²⁾	498 ²⁾
	1.9	Wheelbase	y mm	1,650	1,700	1,780
	Weights	2.1	Net weight	kg	3,640	4,170
2.2		Axle loading, laden front/rear	kg	5,460 / 680	6,370 / 800	7,150 / 900
2.3		Axle loading, unladen front/rear	kg	1,490 / 2,150	1,630 / 2,540	1,700 / 2,850
Wheels / frame	3.1	Tyres		Pneumatic		
	3.2	Tyre size, front	mm	7.00-12	27x10-12	27x10-12
	3.3	Tyre size, rear	mm	6.00x9	6.50x10	6.50x10
	3.5	Wheels, number front/rear (x = driven wheels)		2x/2		
	3.6	Tread width, front	b ₁₀ mm	990	1,034	1,034
	3.7	Tread width, rear	b ₁₁ mm	940		
	Basic dimensions	4.1	Tilt of mast/fork carriage forward/backward		α/β °	
4.2		Mast height (lowered)	h ₁ mm	2,129	2,122	2,201
4.3		Free lift	h ₂ mm	150		
4.4		Lift	h ₃ mm	2,900		
4.5		Extended mast height	h ₄ mm	3,502	3,659	3,689
4.7		Height of overhead guard	h ₆ mm	2,175	2,180	2,180
4.8		Seat height/standing height	h ₇ mm	1,130	1,135	1,135
4.12		Coupling height	h ₁₀ mm	420	430	430
4.19		Overall length	l ₁ mm	3,617	3,768	3,863
4.20		Length to face of forks	l ₂ mm	2,567	2,718	2,813
4.21		Overall width	b ₁ /b ₂ mm	1,192	1,296	1,296
4.22		Fork dimensions	s/e/l mm	40 / 100 / 1,050	45 / 125 / 1,050	50 / 125 / 1,050
4.23		Fork carriage ISO 2328, class/type A, B		2A	3A	3A
4.24		Fork carriage width	b ₃ mm	1,120		
4.31		Floor clearance with load under mast	m ₁ mm	106	104	131
4.32		Ground clearance, centre of wheelbase	m ₂ mm	141	155	153
4.33		Aisle width for pallets 1000 x 1200 crossways	Ast mm	3,987	4,133	4,248
4.34		Aisle width for pallets 800 x 1200 lengthways	Ast mm	4,187	4,333	4,448
4.35		Turning radius	W _a mm	2,315	2,440	2,550
4.36	Smallest turning radius	b ₁₃ mm	720	730	750	
Performance data	5.1	Travel speed, laden/unladen	km/h	18 / 19		
	5.2	Lift speed, laden/unladen	m/s	0.58 / 0.6	0.59 / 0.61	0.5 / 0.52
	5.3	Lowering speed, laden/unladen	m/s	0.55 / 0.55		
	5.5	Drawbar pull, laden/unladen	N	17,000		
	5.7	Gradeability, laden/unladen	%	23 / 27	20 / 26	17 / 24
	5.9.2	Acceleration time laden/unladen to 15 m	S	5.7 / 5	6.2 / 5.4	6.5 / 5.6
	5.10	Service brake		hydraulic		
	5.11	Parking brake		hydraulic		
Combustion engine	7.1	Engine manufacturer / type		Kubota WG2503-L		
	7.2	Engine output according to ISO 1585	kW	36.5		
	7.3	Rated speed	/min	2,200		
	7.4	No. of cylinders		4		
	7.4.1	Cubic capacity	cm ³	2,491		
	7.5	Fuel consumption as per EN 16796	kg/h	3	3.4	4
		CO- Equivalent as per EN 16796	kg/h	10.2	11.5	13.6
Misc.	8.1	Type of drive control		hydrodynamic		
	8.2	Working pressure for attachments	bar	210		
	8.3	Oil flow for attachments	l/min	40		
	8.4	Sound pressure level at operator's ear as per EN 12053	dB (A)	82		
	8.5	Trailer coupling, model/type DIN		Bolt		
	8.6	Steering		hydraulic		

¹⁾ + 12 mm with integrated sideshift

²⁾ + 15 mm with integrated sideshift

DFG/TFG 425/430/435



Standard scope of delivery:

- Operator cab entry handle on upright of overhead load guard.
- Strut roof.
- Demand-driven hydraulic steering with load sensing technology.
- Steering column with adjustable tilt.
- Travel direction lever mounted on steering column.
- Individual hydraulic levers on the panel wall.
- Instrumentation with glare-free display for hour meter and tank capacity.
- Indicator lights for engine oil pressure, coolant temperature, battery charge, parking brake, transmission oil temperature, brake fluid level, neutral display, low fuel level warning (diesel), electronic preheating (diesel) and water in the diesel filter.
- Acoustic warning for excess coolant temperature.
- MSG20 simulated leather seat with automatic lap belt and mechanical cushioning. Setting options: Longitudinal adjustment, backrest tilt and weight adjustment (up to 130 kg).
- Functional storage compartments suitable for everyday use including a drink holder.
- Noise and vibration-reducing rubber floor mat.
- Automotive-style pedal configuration.
- Wet maintenance-free disc brakes with electric parking brake.
- 2 front halogen spotlights and 2 brake/rear lights on rear counterweight.
- Hydraulic control valve incorporating load sensing technology.
- Full-flow hydraulic oil filtration with suction and return filter for maximum oil purity.
- Heavy-duty cyclonic air cleaner.
- Oil cooler for torque converter and transmission oil
- Closed cooling system (pressure system).
- Trailer coupling (tiller bracket) with shunting bar on counterweight.
- Full-length belly plate.

Benefit from the advantages



Entry via a deep, wide step. Large, strong grab handle welded to the overhead guard

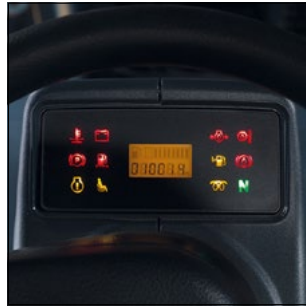

Display in the operator's field of vision



Automotive pedal configuration with non-slip surface



Optimum view of the load thanks to lift mast design giving ideal visibility

Powerful and efficient drive concept

- Proven industrial engines from Kubota in diesel and LPG models.
- Robust and modern engines, designed for durability, high load capacity and reliability.
- High torque at low speeds.
- Engine timing via inclined spur-toothed wheels.
- Engines with low emissions (diesel motors as per Directive 97/68/ EU stage 3A).

Ergonomic operator workstation

- Optimum visibility in all directions.
- Entry and exit via a deep, wide step which is clearly visible from the operator seat.
- Large, strong grab handle welded to the overhead guard.
- Generous knee and legroom thanks to slim and easily adjustable steering column.
- Ergonomic steering wheel offset to the left.
- Effortless operation with hydraulic power-assisted steering.
- Large, level foot-well with vibration-absorbing floor mat.
- Sturdy hydraulic levers positioned for easy use even when wearing gloves.
- Comfortable operator seat with excellent suspension and numerous adjustment options.
- Optimal configuration of display and switches for additional equipment (e.g. lighting and wipers) within the operator's reach and field of vision.
- Numerous storage options, such as drink holder, documents clip and a compartment for every day objects.
- Electric parking brake simply operated at the push of a button without awkward hand lever in knee and entry area.
- Automotive pedal layout with non-slip surface.

Mast and hydraulics

- Smooth transitions provided by the mast cushioning system.
- High residual capacity at high lift heights.
- Optimum view of the load thanks to lift mast design giving ideal visibility.
- Compact section nesting.

- Hydraulic hoses routed for optimum visibility.
- Viewing window in the free lift cylinder cross-member for safe work at higher racking levels.
- Hydraulic control valve incorporating load sensing technology. The load sensing system lowers the energy consumption while simultaneously slowing the deterioration of the oil.

Drive axle with maintenance-free wet-disc brake

- Low consumption through axle concept with optimised efficiency.
- Largely maintenance-free multi-disc brakes immersed in an oil bath – practically no service costs.
- No negative effect on braking due to environmental influences or service related downtime due to the enclosed design.

Uncoupled power train

Improved operator comfort and reduction of human vibrations to a minimum through:

- Floating drive unit.
- Drive shaft combination with universal joints.

Enclosed high-performance cooling system with combi cooler

- Heavy-duty combi cooler in full aluminium design for engine coolant, converter and transmission oil – without the common plastic manifolds which are susceptible to faults.
- Easy cleaning due to vertical arrangement of cooling elements for engine coolant, converter and transmission oil.
- Completely closed system – therefore no coolant evaporation.
- Reliable operation without a reduction in performance even at extreme ambient temperatures.

Ease of service

- Optimum access to engine compartment due to 90° opening and L-shaped cover.
- Side sections and floor plate detachable without the need for tools.
- Minimal truck downtime thanks to simple, rapid and cost-effective maintenance – expert knowledge not required.

- Use of sturdy, high-quality components.
- No truck-specific diagnostic tools or special software required.
- Large fuel filter with water separator.
- Oil change interval of 500 operating hours.

Reliable, heavy-duty electrical equipment

- Splash-proof electrics, plug and connections.
- Easily accessible at all times, compact fuse box on the panel wall in the operator compartment

High-mounted, fully floating axle for high degree of passive safety

Even during dynamic travel, outstanding driving stability through reduced pendulum motion is guaranteed by the high pivot point of the steering axle. This minimises the risk of tipover.

Optimised counterweight design

- The counterweight design displaces the centre of gravity downward and forward.
- The truck's centre of gravity is low and is situated between the front and rear axles.

Additional comfort equipment in different models (optional)

- Windscreen and rear window made of single-pane safety glass.
- Overhead roof panel made of laminated safety glass.
- Heated rear window (with vertical sliding window).
- Wipers and washer system for windscreen and rear window.
- Steel doors with sliding windows.
- Heating including windscreen demisters.
- Panoramic interior mirror.
- Left and right rear view mirrors.
- Armrest.
- Comfort seats in fabric or simulated leather.

Benefit from the advantages



Simple, fast and affordable maintenance



Side sections are easily detachable without tools



Electrically applied parking brake, easily operated at the push of a button



Heating including air demister for windscreen

Benefit from our typical safety and environmental benefits

- Automatic hydraulic and travel interlock when the operator leaves the seat – tilting, lifting, lowering and travelling are only possible when the seat is occupied.
- Acoustic warning signal when the operator's seat is vacated before the parking brake is activated.
- Transmission is automatically placed into neutral as soon as operator leaves the truck.
- All diesel engines comply with the EU exhaust emissions stage 3A regulations.

Jungheinrich UK Ltd.

Head Office:
 Sherbourne House
 Sherbourne Drive
 Tilbrook
 Milton Keynes MK7 8HX
 Telephone 01908 363100
 Fax 01908 363180

info@jungheinrich.co.uk
 www.jungheinrich.co.uk

The German production facilities in Norderstedt, Moosburg and Landsberg are certified. **ISO 9001**
ISO 14001

Jungheinrich fork lift trucks meet European safety requirements.



JUNGHEINRICH